

# JVC

## SERVICE MANUAL

### COMPACT COMPONENT SYSTEM

# FS-SD5 FS-SD7 / FS-SD9

Supplement

Area Suffix

A ..... Australia

**This Supplement is informational about the extension cable, the CD mechanism is information which uses KSM-770 and KSM-900.**

**Please refer the service manual of FS-SD5/FS-SD7/FS-SD9.  
(Issue No. 20830)**

# Method of connecting treatment device wire

This machine is using the mechanism of KSM-770 or KSM-900.  
 Please refer to the following which mechanism to be used.

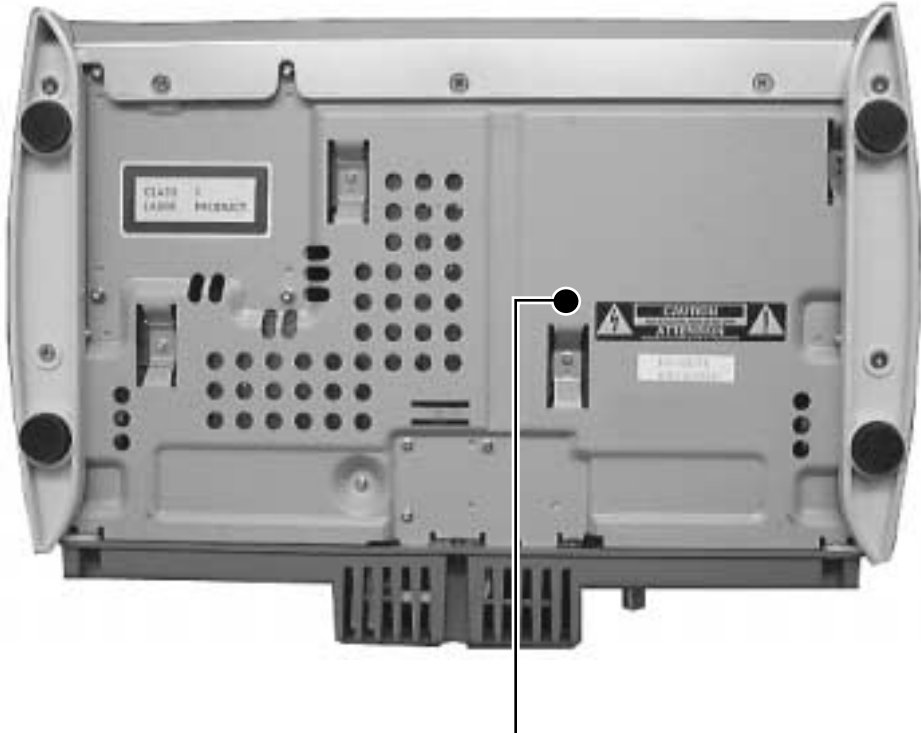

Presence of black seal	Mechanism used
X	KSM-770
O	KSM-900

First short-circuit the pickup circuit before removing the pickup. Then carry out the replacement.  
 Refer to "Dismantling and assembling the traverse unit" on page 1-5.

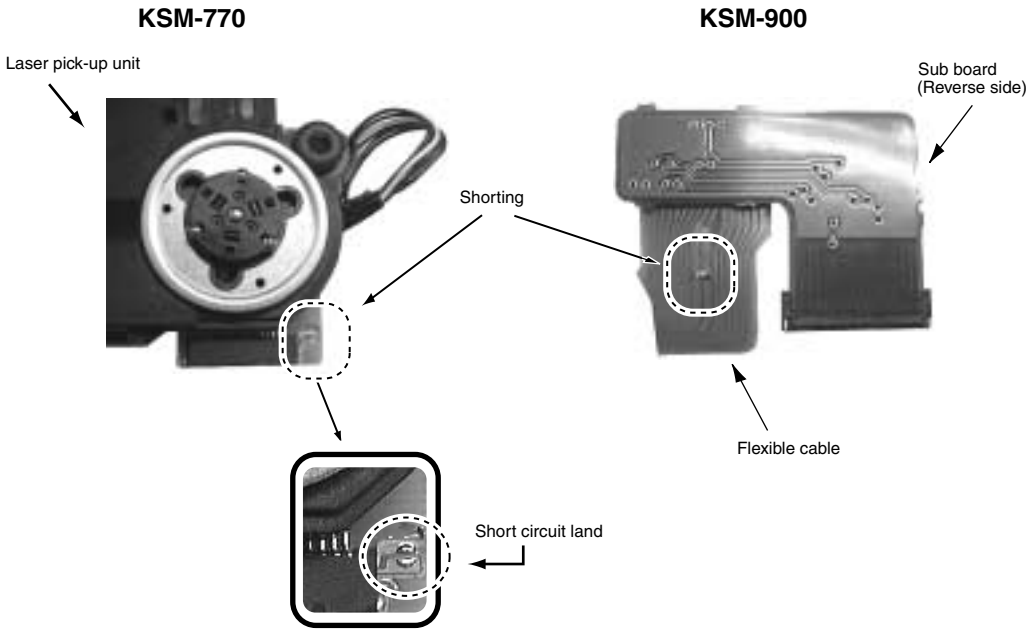

When the KSM-770 mechanism is used, the expansion cable is used as follows.

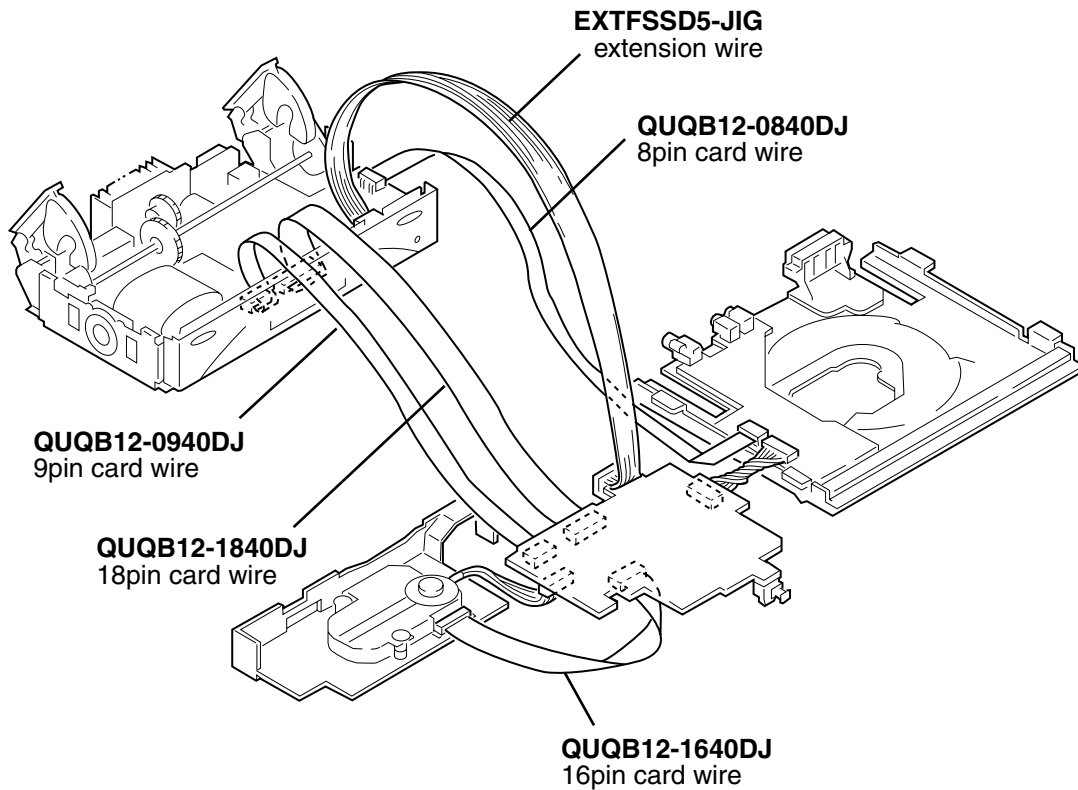

When the KSM-900 mechanism is used, the expansion cable is used as follows.

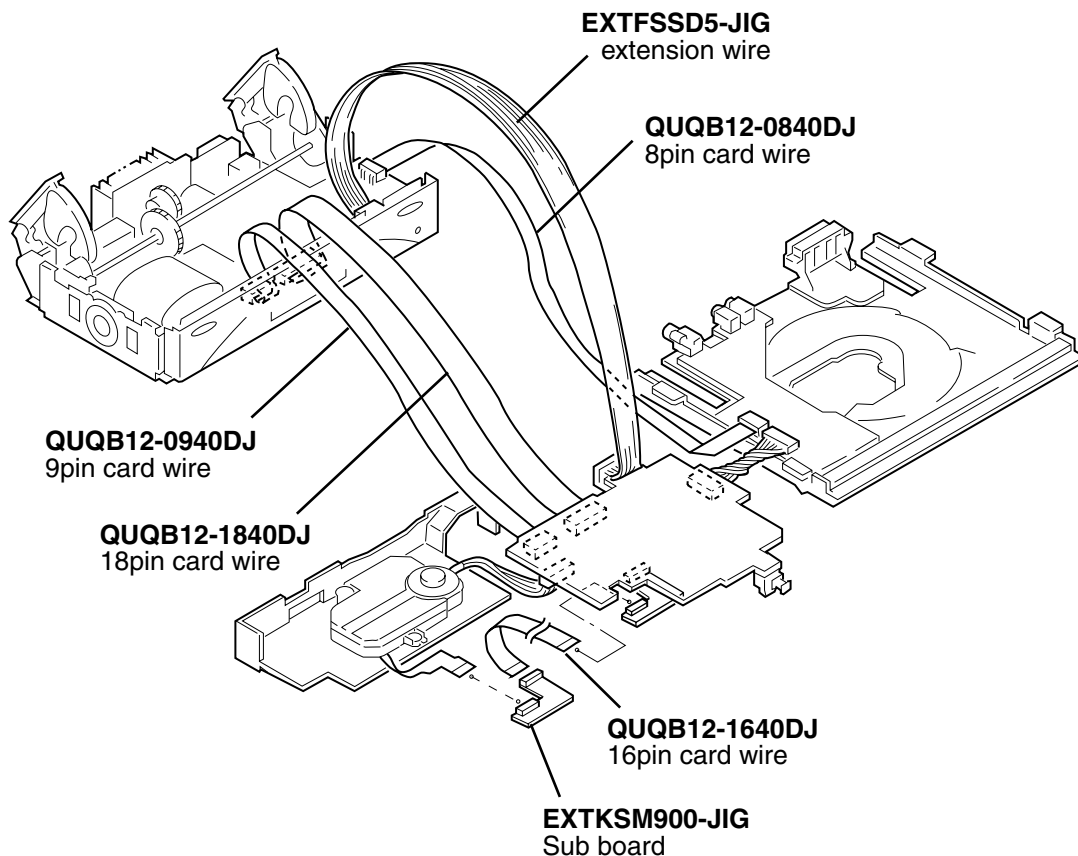

■ CD servo control section (for KSM-900)

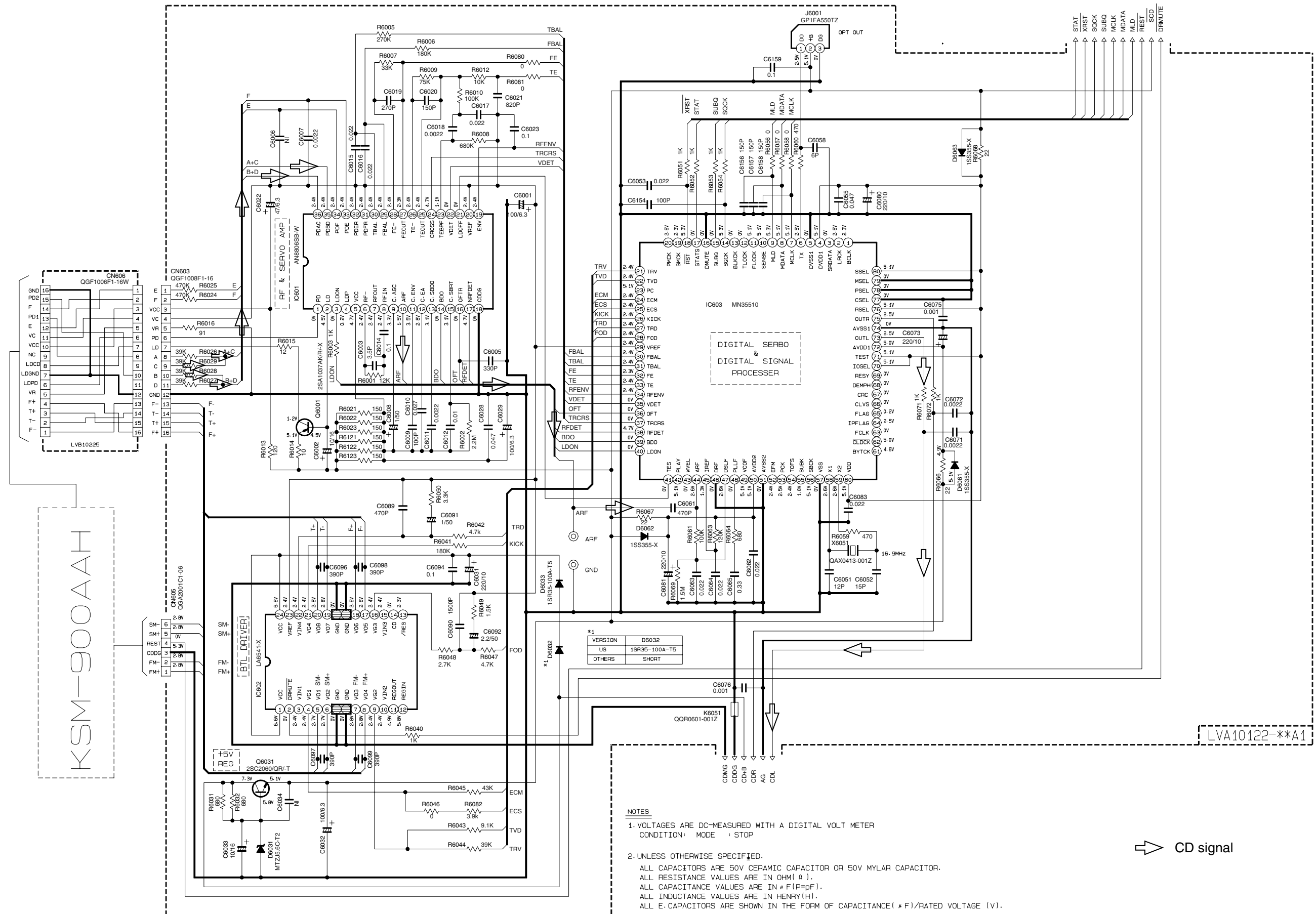

➡ CD signal

■ Parts list(General assembly)

P3-2,P3-4 Block No. M1MM

△	Item	Parts name	Parts number		Remarks
			KSM-770ABA	KSM-900AAH	
	9	CD MECHA	KSM-770ABA	KSM-900AAH	
	11	CD CHASSIS	LV10326-001A	LV10326-002A	
	51	TOP PANEL	LV10327-002A LV10327-004A	LV10327-001A LV10327-003A	FS-SD5/SD7 FS-SD9

■ Electrical parts list(CD board)

P3-9,P3-10 Block No. 02

△	Item	Parts name	Parts number	
			KSM-770ABA	KSM-900AAH
	CN606	CONNECTOR	-----	QGF1006F1-16W
	C6020	C CAPACITOR	NCS21HJ-181X	NCS21HJ-151X
	C6092	NP.E CAPACITOR	QENC1HM-225Z	-----
	R6006	MG RESISTOR	NRSA02J-473X	NRSA02J-184X
	R6007	MG RESISTOR	NRSA02J-273X	NRSA02J-333X
	R6008	MG RESISTOR	-----	NRSA02J-684X
	R6009	MG RESISTOR	NRSA02J-563X	NRSA02J-753X
	R6024	MG RESISTOR	NRSA02J-154X	NRSA02J-474X
	R6025	MG RESISTOR	NRSA02J-154X	NRSA02J-474X
	R6041	MG RESISTOR	NRSA02J-433X	NRSA02J-184X
	R6043	MG RESISTOR	NRSA02J-123X	NRSA02J-912X
	R6044	MG RESISTOR	NRSA02J-683X	NRSA02J-393X
	R6047	MG RESISTOR	NRSA02J-332X	NRSA02J-472X
	R6048	MG RESISTOR	NRSA02J-222X	NRSA02J-272X
	R6049	MG RESISTOR	NRSA02J-152X	-----

**JVC**

VICTOR COMPANY OF JAPAN, LIMITED

AUDIO & COMMUNICATION BUSINESS DIVISION

PERSONAL & MOBILE NETWORK B.U. 10-1, 1chome, Ohwatari-machi, Maebashi-city, 371-8543, Japan